

830-1000

BANBALK SERIE 830
CONVEYOR BEAM SERIE 830
FÜHRUNGSPROFIL SERIE 830

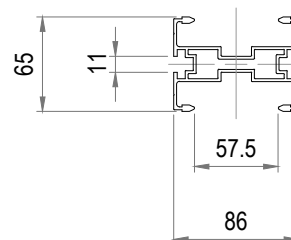

830-1005

BANBALK SERIE 830
CONVEYOR BEAM SERIE 830
FÜHRUNGSPROFIL SERIE 830

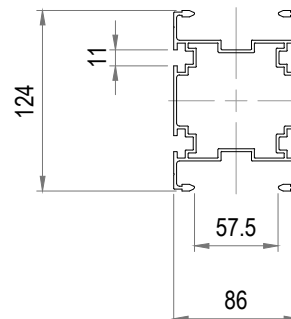

830-1010

KURVBALK SERIE 830
HALF BEAM SERIE 830
HALBES FÜHRUNGSPROFIL SERIE 830

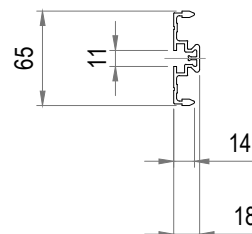

830-1020

BANBALK ÖPPEN SERIE 830
CONVEYOR BEAM OPEN SERIE 830
FÜHRUNGSPROFIL OFFEN SERIE 830

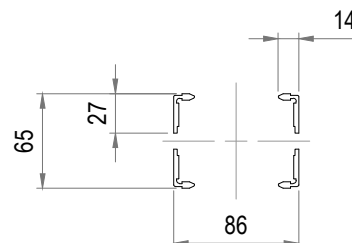

830-1030

KLAMMA FÖR KURVBALK
CLAMP FOR HALF BEAM
KLAMMER FÜR HALBES FÜHRUNGSPROFIL

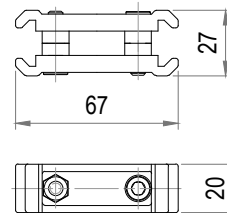

830-1040

DISTANS ÖPPEN PROFIL
SPACER OPEN PROFILE
DISTANZ OFFEN PROFIL

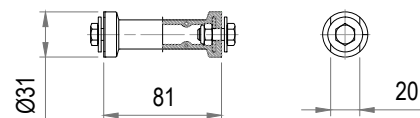

830-1050

LISTFÄSTE ÖPPEN PROFIL
STRIP ATTACHEMENT OPEN PROFILE
VERBINDUNGSSTÜCK OFFEN PROFIL

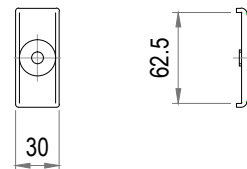

KEDJOR

FÖR ANNAT KEDJEMATERIAL ÄN STANDARD VIT ACETAL ANGES TILLÄGGSBOSKTAV

L = LÅGFRIKTION

V = VÄRMEBESTÄNDIG

A = ANTISTATISK

F = FLOCKAD

BESTÄLLNINGSEXEMPEL 830-2000L

CHAINS

FOR OTHER CHAINS MATERIAL THAN STANDARD WHITE ACETAL ADD LETTER

L = LOW FRICTION

V = HEAT RESISTENT

A = ANTISTATIC

F = FLOCKED

ORDER EXEMPEL 830-2000L

KETTEN

AUS ANDEREN VOM STANDARD ACETAL ABWEICHENDEN MATERIALEN

L = GERINGE FRIKTION

V = WÄRMEBESTÄNDIGKEIT

A = ANTISTATISCH

F = BEFLOCKT

BESTÄLLBEISPIEL 830-2000L

830-2000

FINGERKEDJA FÖR SERIE 830 OCH 530
FINGER CHAIN FOR SERIE 830 AND 530
FINGERKETTE FÜR SERIE 830 UND 530

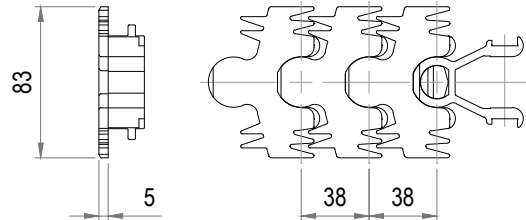

830-2005

DELTAKEDJA FÖR SERIE 830 OCH 530
DELTA CHAIN FOR SERIE 830 AND 530
DELTAKETTE FÜR SERIE 830 UND 530

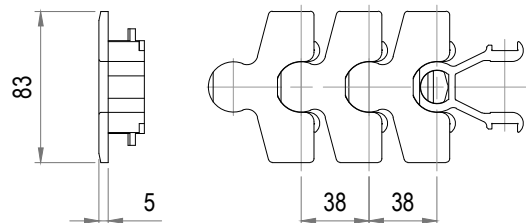

830-2010

FRIKTIONSKEDJA FÖR SERIE 830 OCH 530
FRICTION CHAIN FOR SERIE 830 AND 530
FRIKTIONSKETTE FÜR SERIE 830 UND 530

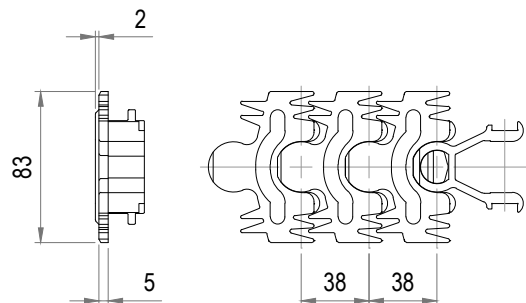

830-2020

FRIKTIONSKEDJA FÖR SERIE 830 OCH 530
FRICTION CHAIN FOR SERIE 830 AND 530
FRIKTIONSKETTE FÜR SERIE 830 UND 530

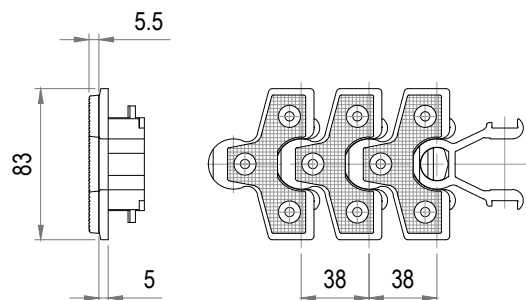

830-2030

KLÄMKEDJA FÖR SERIE 830 OCH 530
SIDE GRIP CHAIN FOR SERIE 830 AND 530
KETTE FÜR KLEMMTRANSPORT FÜR SERIE 830 UND 530

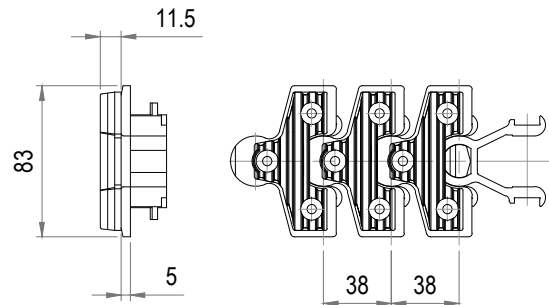

830-2035

KLÄMKEDJA FÖR SERIE 830 OCH 530
SIDE GRIP CHAIN FOR SERIE 830 AND 530
KETTE FÜR KLEMMTRANSPORT FÜR SERIE 830 UND 530

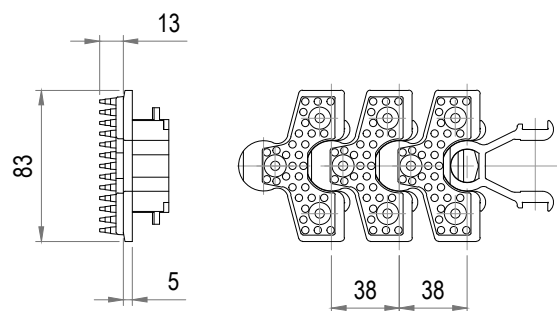

830-2040

KLÄMKEDJA FÖR SERIE 830 OCH 530
SIDE GRIP CHAIN FOR SERIE 830 AND 530
KETTE FÜR KLEMMTRANSPORT FÜR SERIE 830 UND 530

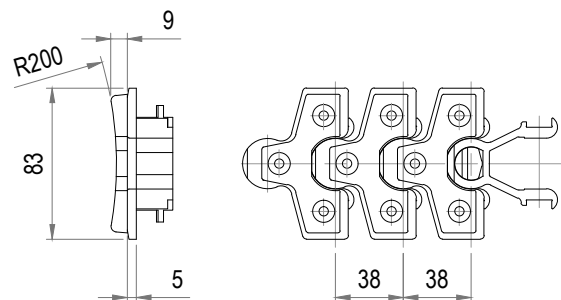

830-2050

KEDJA MED RULLAR FÖR SERIE 830 OCH 530
CHAIN WITH ROLLS FOR SERIE 830 AND 530
KETTE MIT ROLLEN FÜR SERIE 830 UND 530

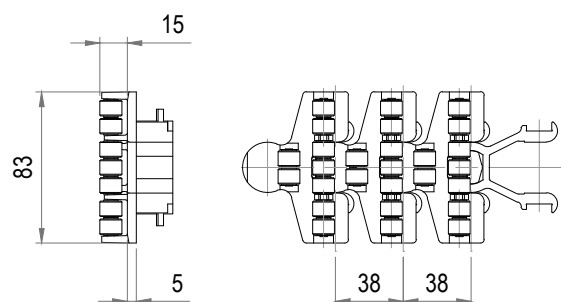

830-2055

RIBBKEDJA FÖR SERIE 830 OCH 530
CHAIN FOR SERIE 830 AND 530
KETTE FÜR SERIE 830 UND 530

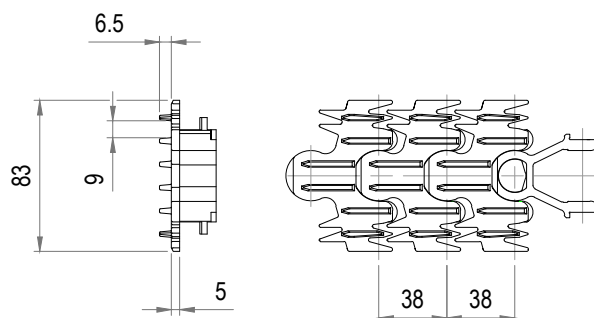

830-2060

LOCK FÖR MEDBRINGARE SERIE 830 OCH 530
TOPFLIGHT FOR CARRIER SERIE 830 AND 530
KOPFPLATTE FÜR MITNEHMER SERIE 830 UND 530

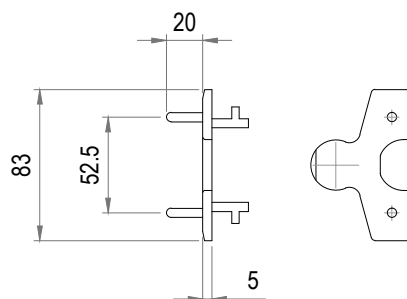

830-2065

LOCK FÖR MEDBRINGARE SERIE 830 OCH 530
TOPFLIGHT FOR CARRIER SERIE 830 AND 530
KOPFPLATTE FÜR MITNEHMER SERIE 830 UND 530

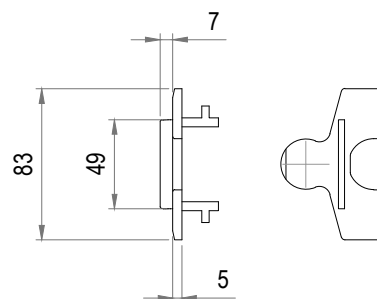

830-2070

LOCK FÖR MEDBRINGARE SERIE 830 OCH 530
TOPFLIGHT FOR CARRIER SERIE 830 AND 530
KOPFPLATTE FÜR MITNEHMER SERIE 830 UND 530

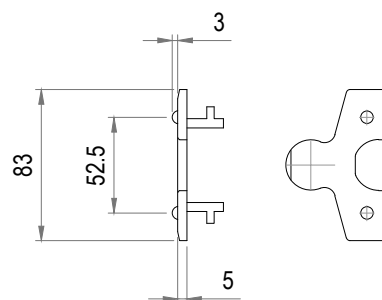

830-2075

LOCK FÖR MEDBRINGARE SERIE 830 OCH 530
TOPFLIGHT FOR CARRIER SERIE 830 AND 530
KOPFPLATTE FÜR MITNEHMER SERIE 830 UND 530

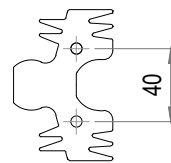

830-2078

MEDBRINGARE MED RULLE
CARRIER WITH ROLLER
MITNEHMER MIT ROLLE

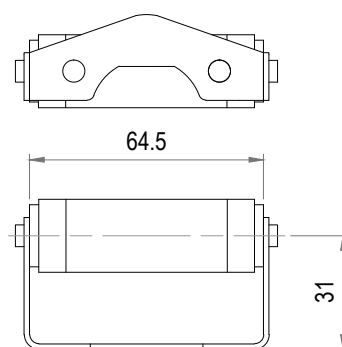

830-2079

LOCK MED RULLMEDBRINGARE SERIE 830 OCH 530
TOPFLIGHT WITH ROLLERCARRIER SERIE 830 AND 530
KOPFPLATTE MIT ROLLEMITNEHMER SERIE 830 UND 530

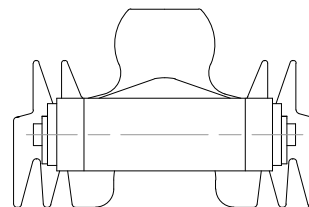
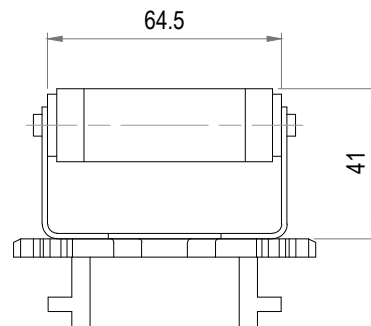

830-2080

MEDBRINGARE
CARRIER
MITNEHMER

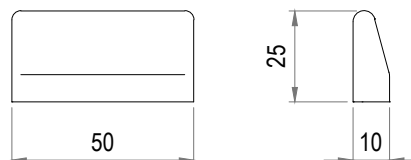

830-2081

LOCK MED MEDBRINGARE SERIE 830 OCH 530
TOPFLIGHT WITH CARRIER SERIE 830 AND 530
KOPFPLATTE MIT MITNEHMER SERIE 830 UND 530

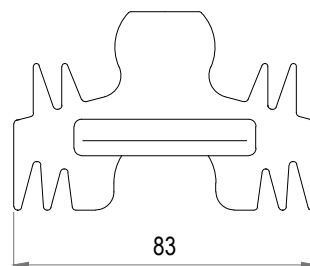
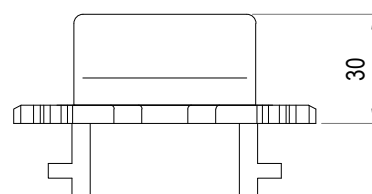

830-2090

DISTANSBRICKA FÖR MEDBRINGARE
SPACER FOR CARRIER
Distanz für Mitnehmer

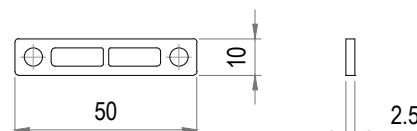

830-2100

FRIKTIONSKEDJA SERIE 830 OCH 530
FRICTION CHAIN SERIE 830 AND 530
FRIKTIONKETTE SERIE 830 UND 530

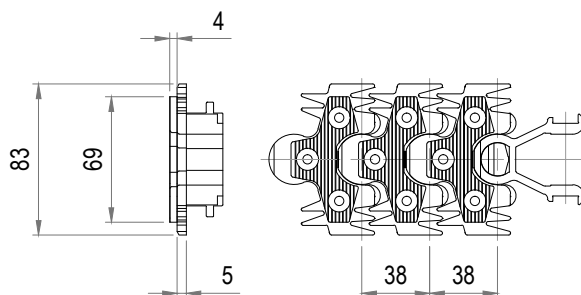

830-2110

KLÄMKEDJA SERIE 830 OCH 530
SIDE GRIP CHAIN SERIE 830 AND 530
KETTE FÜR KLEMMTRANSPORT SERIE 830 UND 530

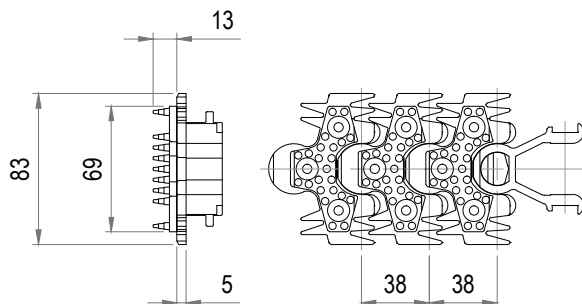

830-2120

KLÄMKEDJA FÖR SERIE 830 OCH 530
SIDE GRIP CHAIN FOR SERIE 830 AND 530
KETTE FÜR KLEMMTRANSPORT FÜR SERIE 830 UND 530

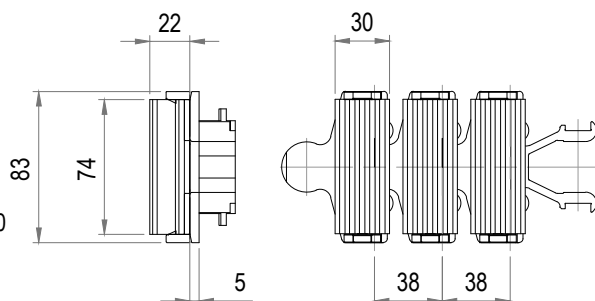

830-2122

KLÄMMBELÄGG FÖR KEDJA 830-2120
SIDE GRIP FOR CHAIN 830-2120
GUMMIBLOCK FÜR KETTE 830-2120

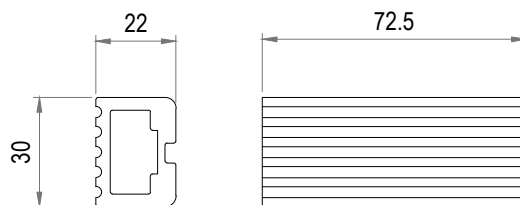

830-2123

LÅSSKENA FÖR 830-2122
LOCKING RAIL FOR 830-2122
SCHLOSSCHIENE FÜR 830-2122

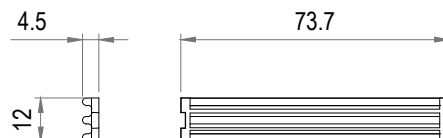

830-310V/H

DRIVSTATION MED ABB/BENZLER SERIE 830
DRIVE UNIT WITH ABB/BENZLER SERIE 830
ANTRIEBSSTATION MIT ABB/BENZLER SERIE 830

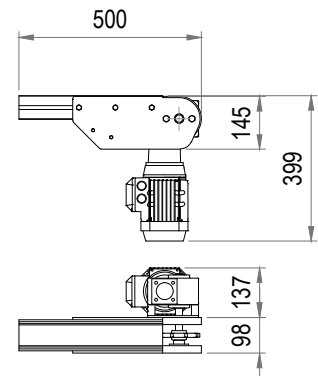

830-315V/H

DRIVSTATION MED ABB/BENZLER SERIE 830
DRIVE UNIT WITH ABB/BENZLER SERIE 830
ANTRIEBSSTATION MIT ABB/BENZLER SERIE 830

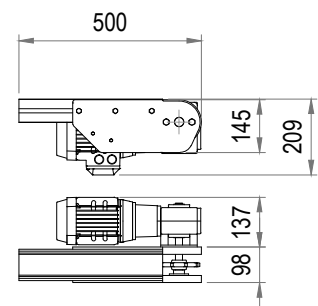

830-320V/H

DRIVSTATION MED ABB/BENZLER FÖR KLÄMTRANSPORTÖR SERIE 830
DRIVE UNIT WITH ABB/BENZLER FOR SIDE GRIP-CONVEYOR SERIE 830
ANTRIEBSSTATION MIT ABB/BENZLER FÜR KLEMMTRANSPORT
FÖDERBAHN SERIE 830

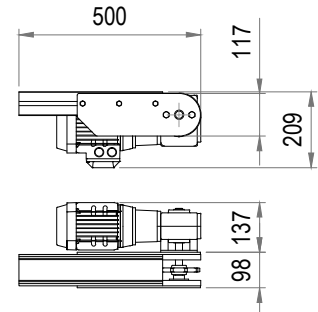

830-324V/H

DRIVSTATION MED UNDERHÄNGANDE DRIFT SERIE 830
DRIVE UNIT WITH SUSPENDED GEARBOX SERIE 830
ANTRIEBSSTATION MIT UNTENLIEGENDEM GETRIEBE SERIE 830

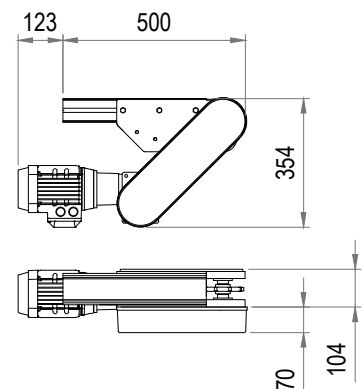

830-325V/H

DRIVSTATION FÖRBEREDD FÖR UNDERHÄNGANDE VÄXELLÅDA SERIE 830
DRIVE UNIT PREPARED FOR SUSPENDED GEARBOX SERIE 830
ANTRIEBSSTATION VORBEREITET FÜR UNTENLIEGENDEM GETRIEBE SERIE 830

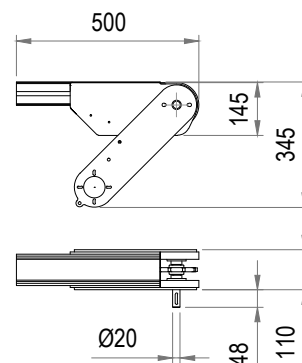

830-330V/H

MITTDRIV MED RETURKEDJA SERIE 830
INTERMEDIATE DRIVE SERIE 830
MITTELANTRIEB SERIE 830

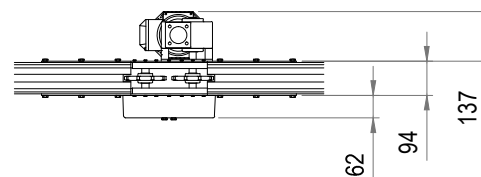
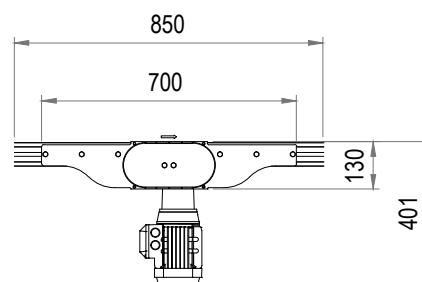

830-335V/H

DRIVSTATION, DRIFT PÅ VÄNSTER/HÖGER SIDA SERIE 830
DRIVE UNIT, TRANSMISSION ON LEFT/RIGHT HAND SIDE SERIE 830
ANTRIEBSSTATION, GETRIEBE AUF LINKER/RECHT SEITE SERIE 830

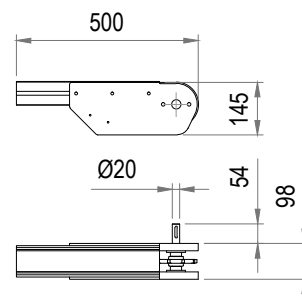

830-345V/H

DRIVSTATION RUNDGÅENDE TRANSPORTÖR SERIE 830
CATENARY DRIVE UNIT SERIE 830
ANTRIEBSSTATION FÜR RUNDGANG SERIE 830

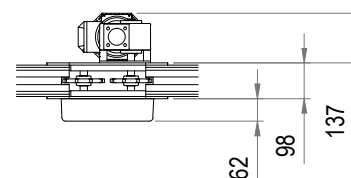
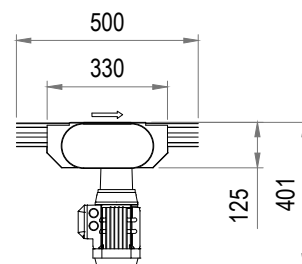

830-350V/H

DRIVSTATION MED SEW SA37 SERIE 830
DRIVE UNIT WITH SEW SA37 SERIE 830
ANTRIEBSSTATION MIT SEW SA37 SERIE 830

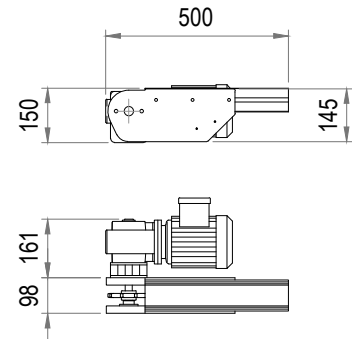

830-355V/H

DRIVSTATION MED SEW SA37 SERIE 830
DRIVE UNIT WITH SEW SA37 SERIE 830
ANTRIEBSSTATION MIT SEW SA37 SERIE 830

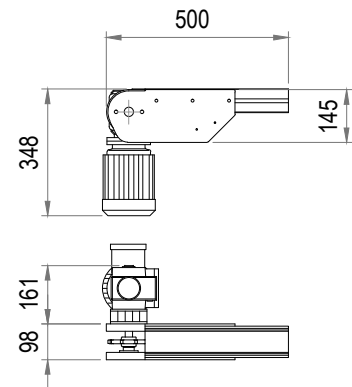

830-360V/H

DRIVSTATION MED SEW WA20 SERIE 830
DRIVE UNIT WITH SEW WA20 SERIE 830
ANTRIEBSSTATION MIT SEW WA20 SERIE 830

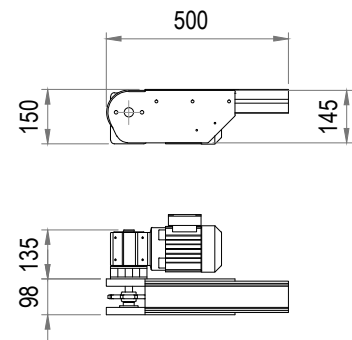

830-365V/H

DRIVSTATION MED SEW WA20 SERIE 830
DRIVE UNIT WITH SEW WA20 SERIE 830
ANTRIEBSSTATION MIT SEW WA20 SERIE 830

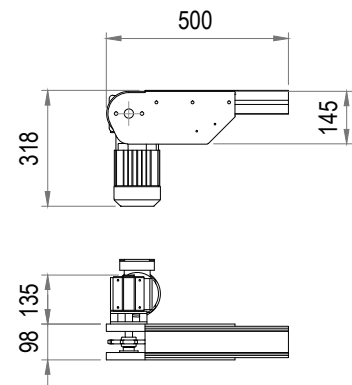

830-370V/H

DRIVSTATION MED SEW WA30 SERIE 830
DRIVE UNIT WITH SEW WA30 SERIE 830
ANTRIEBSSTATION MIT SEW WA30 SERIE 830

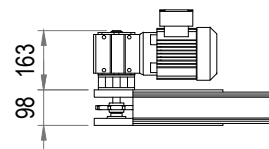
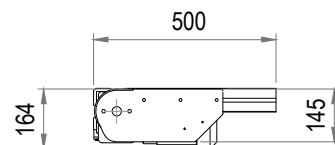

830-375V/H

DRIVSTATION MED SEW WA30 SERIE 830
DRIVE UNIT WITH SEW WA30 SERIE 830
ANTRIEBSSTATION MIT SEW WA30 SERIE 830

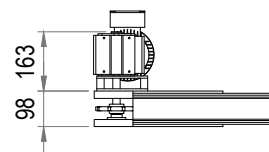
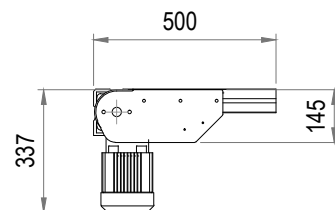

830-380V/H

DRIVSTATION SERIE 830
DRIVE UNIT SERIE 830
ANTRIEBSSTATION SERIE 830

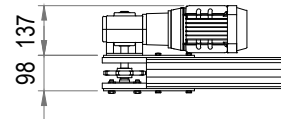
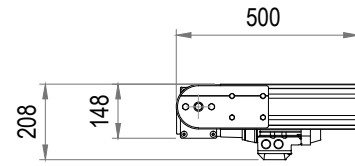

830-385V/H

DRIVSTATION SERIE 830
DRIVE UNIT SERIE 830
ANTRIEBSSTATION SERIE 830

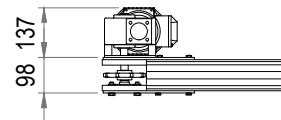
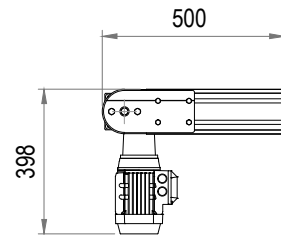

830-390V/H

DRIVSTATION SERIE 830
DRIVE UNIT SERIE 830
ANTRIEBSSTATION SERIE 830

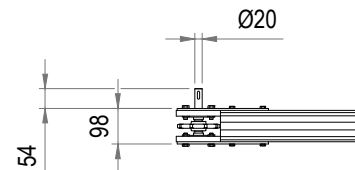
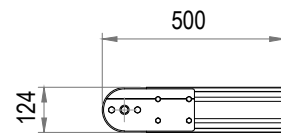

830-4000

VÄNDENHET SERIE 830
IDLER UNIT SERIE 830
UMLENKEINHEIT SERIE 830

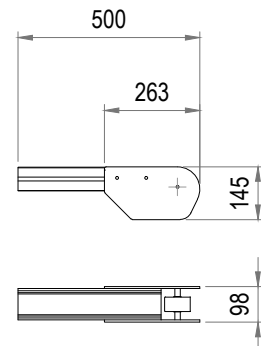

830-4010

VÄNDENHET FÖR KLÄMTRANSPORTÖR SERIE 830
IDLER UNIT FOR SIDE GRIP-CONVEYOR SERIE 830
UMLENKEINHEIT FÜR KLEMMTRANSPORT FÖDERBAHN SERIE 830

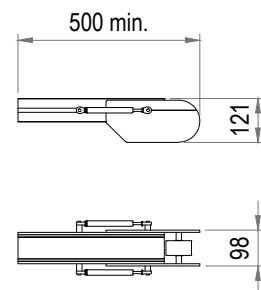

830-4030

VÄNDENHET SERIE 830
IDLER UNIT SERIE 830
UMLENKEINHEIT SERIE 830

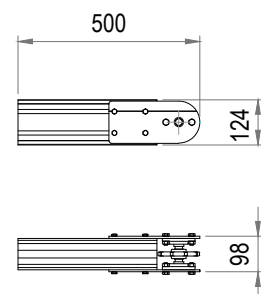

830-4040

VÄNDENHET 90° SERIE 830
IDLER UNIT 90° SERIE 830
UMLENKEINHEIT 90° SERIE 830

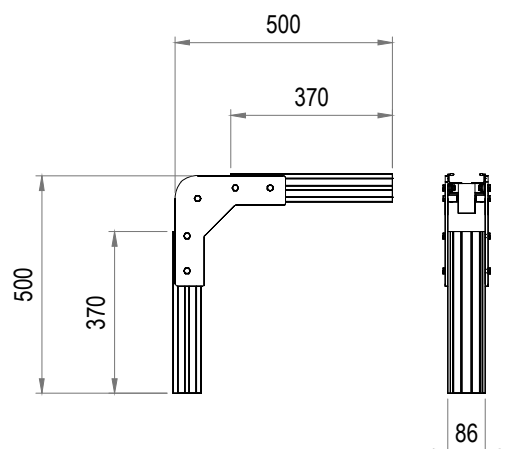

830-4050

VÄNDENHET FÖR DRIVENHET 830-330V/H SERIE 830
IDLER UNIT FOR DRIVE UNIT 830-330V/H SERIE 830
UMLLENKEINHEIT FÜR ANTRIEB 830-330V/H SERIE 830

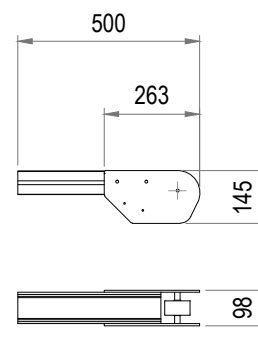

830-5000

HJULKURVA 45° SERIE 830
WHEELCURVE 45° SERIE 830
RADBOGEN 45° SERIE 830

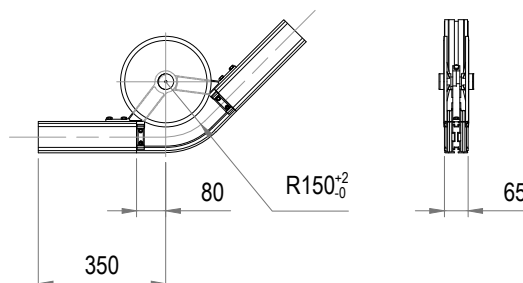

830-5010

HJULKURVA 90° SERIE 830
WHEELCURVE 90° SERIE 830
RADBOGEN 90° SERIE 830

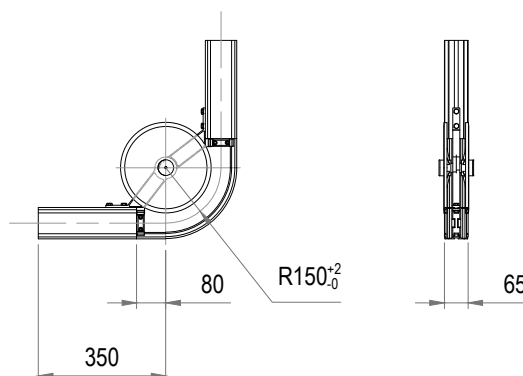

830-5020

HJULKURVA 180° SERIE 830
WHEELCURVE 180° SERIE 830
RADBOGEN 180° SERIE 830

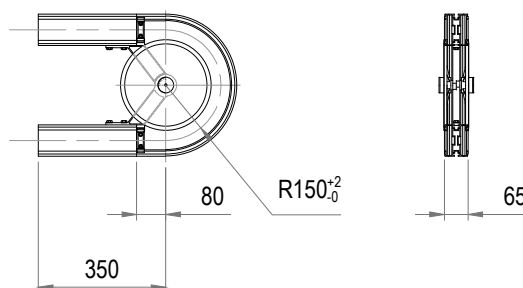

830-5025

HJULKURVA X° SERIE 830
WHEELCURVE X° SERIE 830
RADBOGEN X° SERIE 830

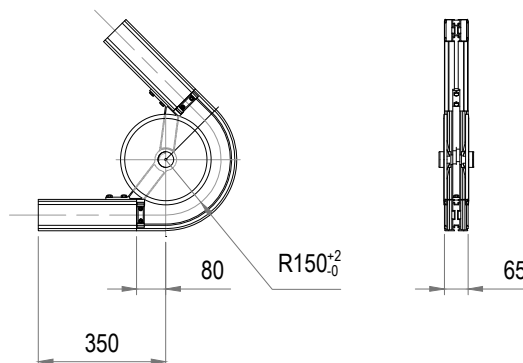

830-5026

KURVSTATIV FÖR HJULKURVA R150 SERIE 830
ADJUSTABLE SUPPORT ASSEMBLY R150 SERIE 830
LAGERSTREBEN FÜR RADBOGEN R150 SERIE 830

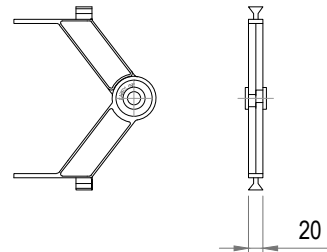

830-5027

TALLRIK TILL HJULKURVA R150
WHEELCURVE DISC R150
TELLER FÜR RADBOGEN R150

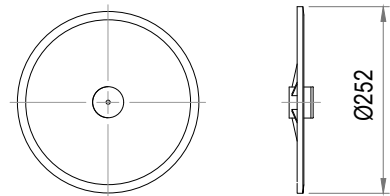

830-5028

AXEL TILL HJULKURVA R150
SHAFT FOR WHEELCURVE R150
WELLE FÜR RADBOGEN R150

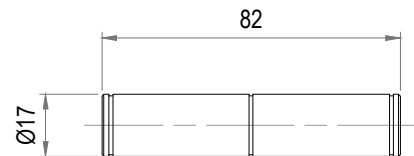

830-5029

KLÄMSKYDD FÖR HJULKURVA R150
PINCH GUARD FOR WHEELCURVE R150
KLEMMABDECKUNG FÜR RADBOGEN R150

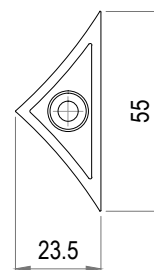

830-5031

PLASTKÅPA FÖR TALLRIK R150 SERIE 830
PLASTIC COVER FOR WHEEL CURVE DISC R150 SERIE 830
KUNSTGLASWANNE FÜR TELLER R150 SERIE 830

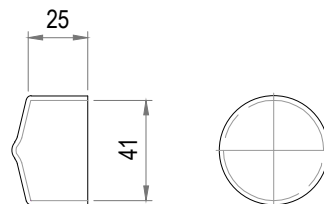

830-5035

HJULKURVA 45° SERIE 830
WHEELCURVE 45° SERIE 830
RADBOGEN 45° SERIE 830

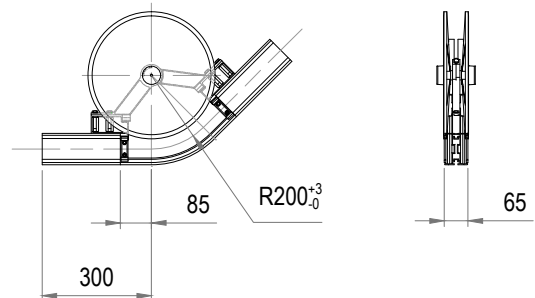

830-5040

HJULKURVA 90° SERIE 830
WHEELCURVE 90° SERIE 830
RADBOGEN 90° SERIE 830

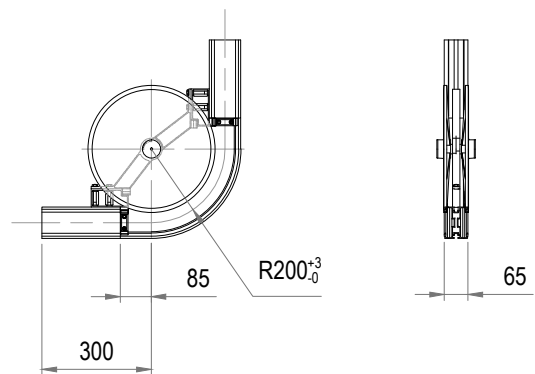

830-5050

HJULKURVA 180° SERIE 830
WHEELCURVE 180° SERIE 830
RADBOGEN 180° SERIE 830

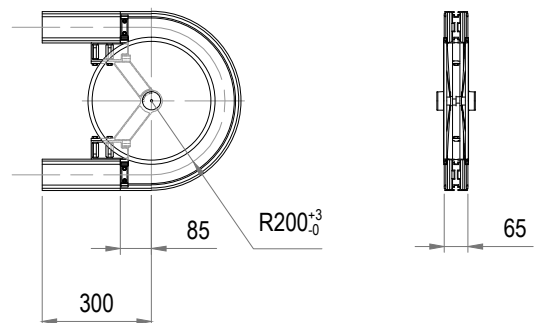

830-5055

HJULKURVA X° SERIE 830
WHEELCURVE X° SERIE 830
RADBOGEN X° SERIE 830

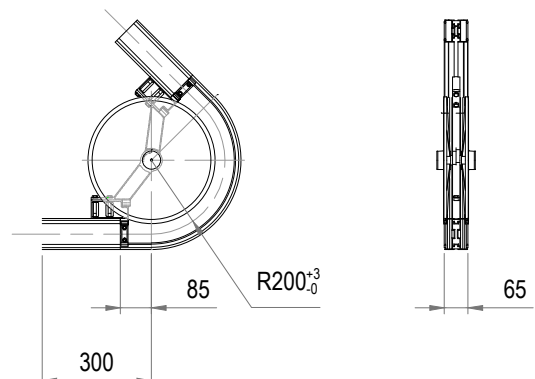

830-5056

KURVSTATIV FÖR HJULKURVA R200 SERIE 830
ADJUSTABLE SUPPORT ASSEMBLY R200 SERIE 830
LAGERSTREBEN FÜR RADBOGEN R200 SERIE 830

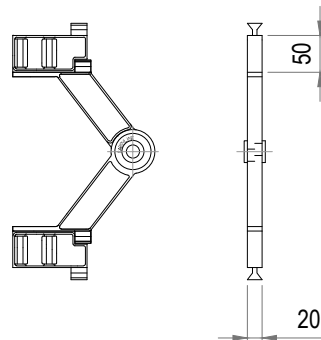

830-5057

DISTANSKLOSS TILL KURVSTATIV
SPACING BLOCK FOR ADJUSTABLE SUPPORT
ABSTANDHALTER FÜR LAGERSTREBEN

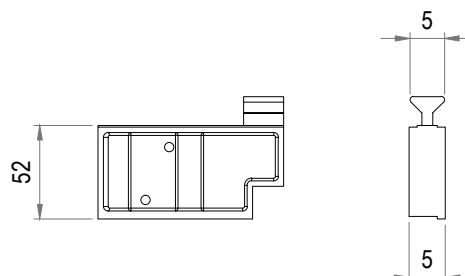

830-5058

AXEL TILL HJULKURVA R200
SHAFT FOR WHEELCURVE R200
WELLE FÜR RADBOGEN R200

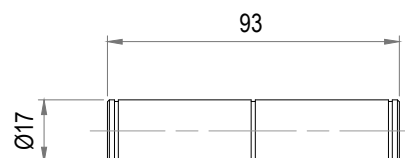

830-5059

KLÄMSKYDD FÖR HJULKURVA R200
PINCH GUARD FOR WHEELCURVE R200
KLEMMABDECKUNG FÜR RADBOGEN R200

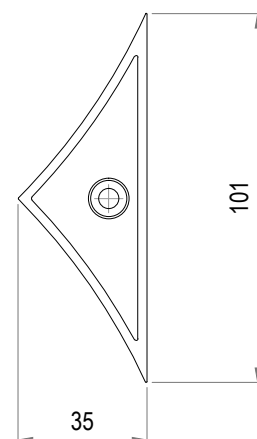

830-5060

TALLRIK TILL HJULKURVA R200
WHEELCURVE DISC R200
TELLER FÜR RADBOGEN R200

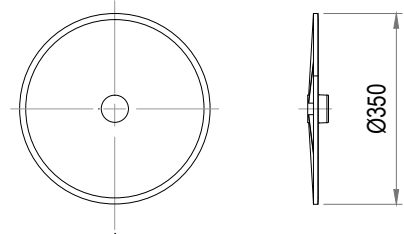

830-5062

PLASTKÅPA FÖR TALLRIK R200 SERIE 830
PLASTIC COVER FOR WHEEL CURVE DISC R200 SERIE 830
KUNSTGLASWANNE FÜR TELLER R200 SERIE 830

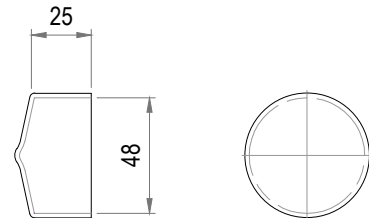

830-5080

GLIDKURVA 15° SERIE 830
PLAIN BEND 15° SERIE 830
GLEITBOGEN 15° SERIE 830



830-5090

GLIDKURVA 30° SERIE 830
PLAIN BEND 30° SERIE 830
GLEITBOGEN 30° SERIE 830



830-5100

GLIDKURVA 45° SERIE 830
PLAIN BEND 45° SERIE 830
GLEITBOGEN 45° SERIE 830

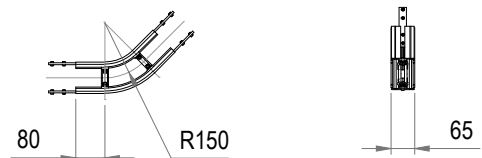

830-5110

GLIDKURVA 90° SERIE 830
PLAIN BEND 90° SERIE 830
GLEITBOGEN 90° SERIE 830

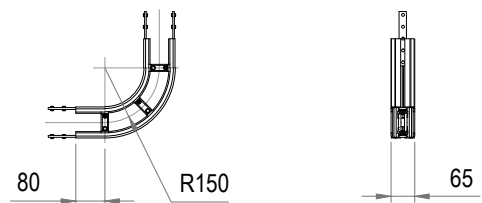

830-5120

GLIDKURVA 180° SERIE 830
PLAIN BEND 180° SERIE 830
GLEITBOGEN 180° SERIE 830

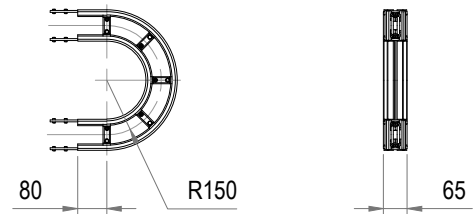

830-5130

GLIDKURVA 15° SERIE 830
PLAIN BEND 15° SERIE 830
GLEITBOGEN 15° SERIE 830



830-5140

GLIDKURVA 30° SERIE 830
PLAIN BEND 30° SERIE 830
GLEITBOGEN 30° SERIE 830



830-5150

GLIDKURVA 45° SERIE 830
PLAIN BEND 45° SERIE 830
GLEITBOGEN 45° SERIE 830

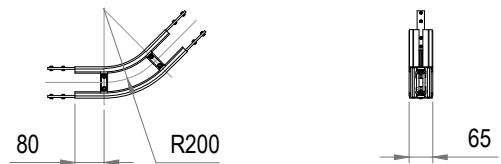

830-5160

GLIDKURVA 90° SERIE 830
PLAIN BEND 90° SERIE 830
GLEITBOGEN 90° SERIE 830

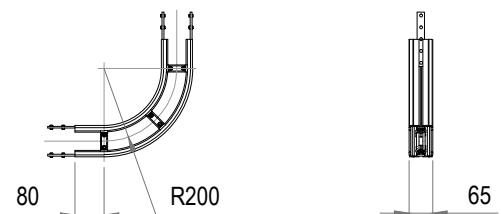

830-5170

GLIDKURVA 180° SERIE 830
PLAIN BEND 180° SERIE 830
GLEITBOGEN 180° SERIE 830

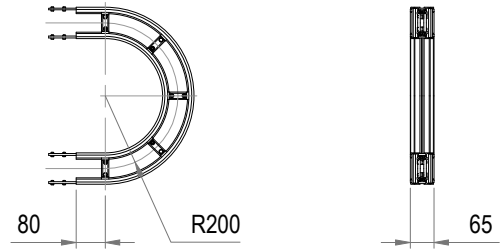

830-5180

GLIDKURVA 15° SERIE 830
PLAIN BEND 15° SERIE 830
GLEITBOGEN 15° SERIE 830

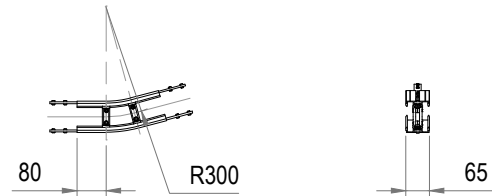

830-5190

GLIDKURVA 30° SERIE 830
PLAIN BEND 30° SERIE 830
GLEITBOGEN 30° SERIE 830

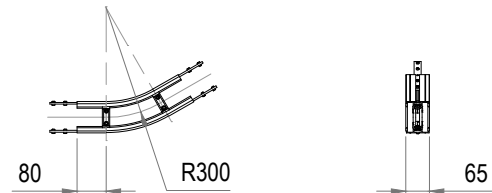

830-5200

GLIDKURVA 45° SERIE 830
PLAIN BEND 45° SERIE 830
GLEITBOGEN 45° SERIE 830

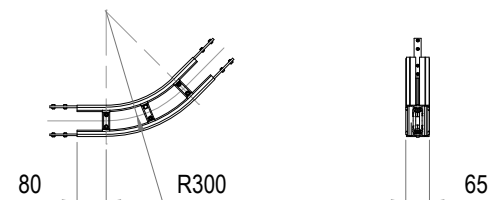

830-5210

GLIDKURVA 90° SERIE 830
PLAIN BEND 90° SERIE 830
GLEITBOGEN 90° SERIE 830

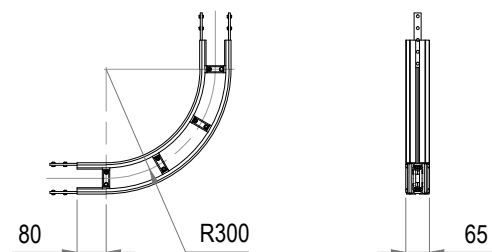

830-5220

GLIDKURVA 180° SERIE 830
PLAIN BEND 180° SERIE 830
GLEITBOGEN 180° SERIE 830

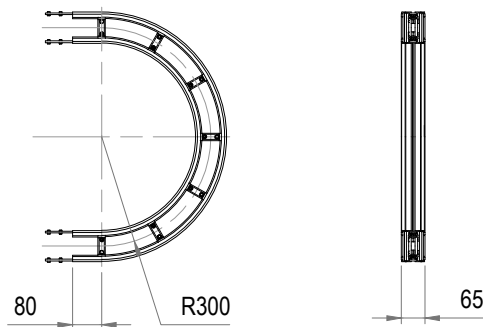

830-5230

GLIDKURVA 15° SERIE 830
PLAIN BEND 15° SERIE 830
GLEITBOGEN 15° SERIE 830

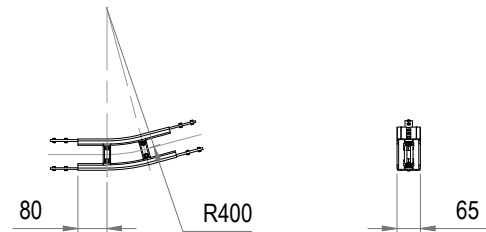

830-5240

GLIDKURVA 30° SERIE 830
PLAIN BEND 30° SERIE 830
GLEITBOGEN 30° SERIE 830

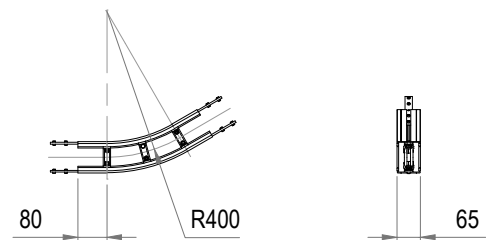

830-5250

GLIDKURVA 45° SERIE 830
PLAIN BEND 45° SERIE 830
GLEITBOGEN 45° SERIE 830

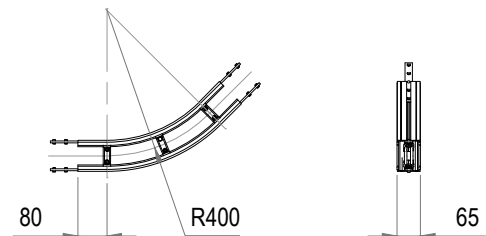

830-5260

GLIDKURVA 90° SERIE 830
PLAIN BEND 90° SERIE 830
GLEITBOGEN 90° SERIE 830

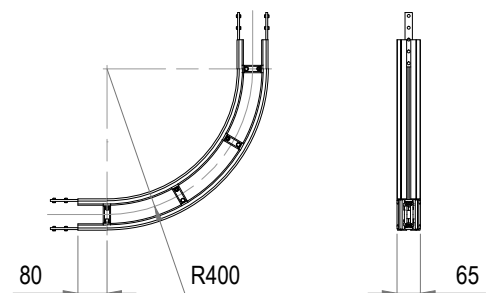

830-5270

GLIDKURVA 180° SERIE 830
PLAIN BEND 180° SERIE 830
GLEITBOGEN 180° SERIE 830

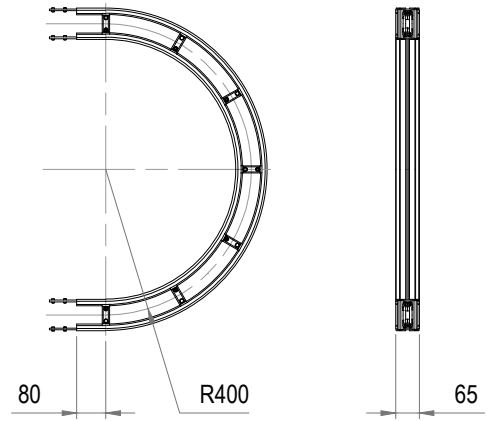

830-5280

GLIDKURVA 15° SERIE 830
PLAIN BEND 15° SERIE 830
GLEITBOGEN 15° SERIE 830

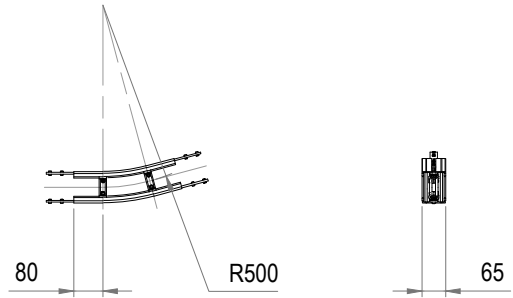

830-5290

GLIDKURVA 30° SERIE 830
PLAIN BEND 30° SERIE 830
GLEITBOGEN 30° SERIE 830

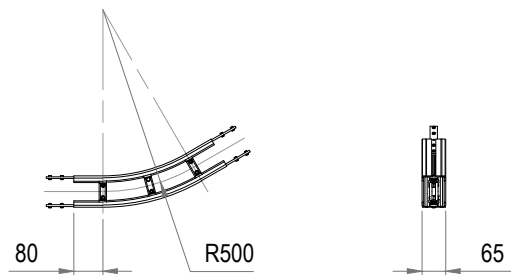

830-5300

GLIDKURVA 45° SERIE 830
PLAIN BEND 45° SERIE 830
GLEITBOGEN 45° SERIE 830

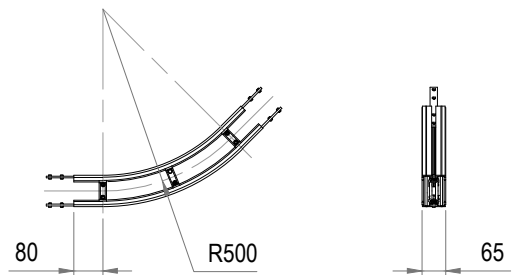

830-5310

GLIDKURVA 90° SERIE 830
PLAIN BEND 90° SERIE 830
GLEITBOGEN 90° SERIE 830

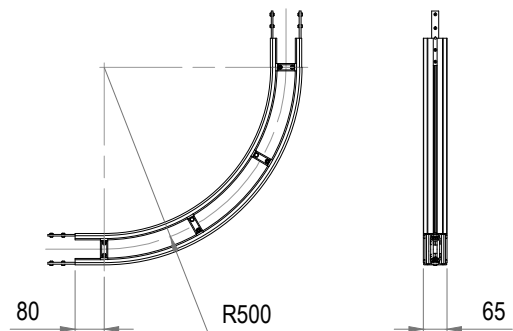

830-5320

GLIDKURVA 180° SERIE 830
PLAIN BEND 180° SERIE 830
GLEITBOGEN 180° SERIE 830

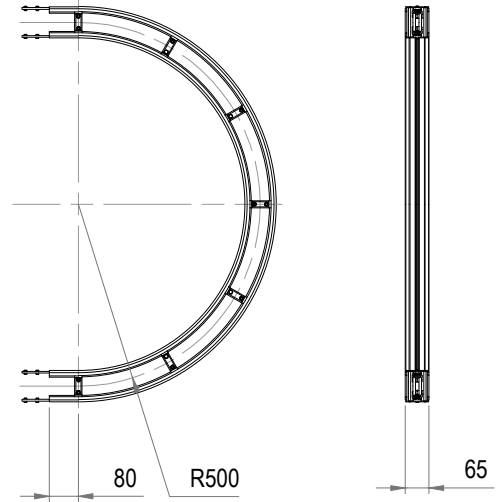

830-5330

GLIDKURVA 15° SERIE 830
PLAIN BEND 15° SERIE 830
GLEITBOGEN 15° SERIE 830

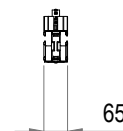
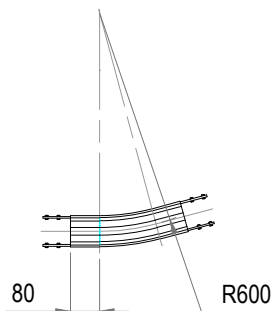

830-5340

GLIDKURVA 30° SERIE 830
PLAIN BEND 30° SERIE 830
GLEITBOGEN 30° SERIE 830

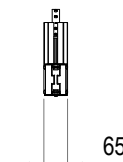
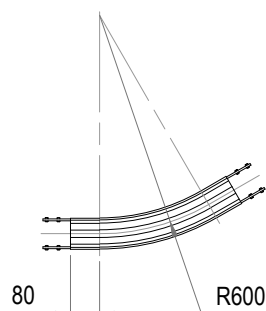

830-5350

GLIDKURVA 45° SERIE 830
PLAIN BEND 45° SERIE 830
GLEITBOGEN 45° SERIE 830

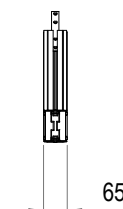
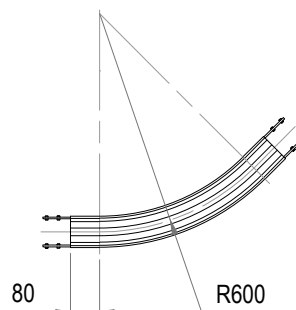

830-5360

GLIDKURVA 90° SERIE 830
PLAIN BEND 90° SERIE 830
GLEITBOGEN 90° SERIE 830

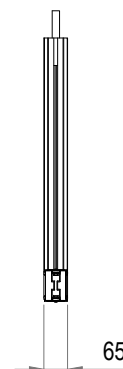
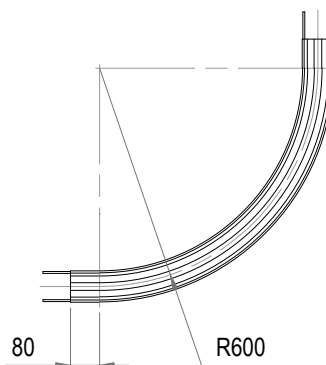

830-5370

GLIDKURVA 180° SERIE 830
PLAIN BEND 180° SERIE 830
GLEITBOGEN 180° SERIE 830

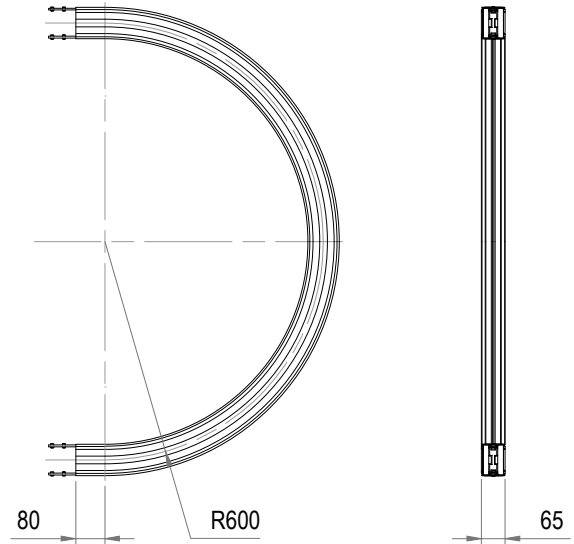

830-5375

GLIDKURVA X° SERIE 830
PLAIN BEND X° SERIE 830
GLEITBOGEN X° SERIE 830

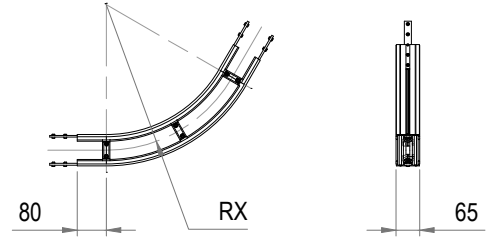

830-5610

VERTIKALKURVA 30° SERIE 830
VERTICAL BEND 30° SERIE 830
VERTIKALBOGEN 30° SERIE 830

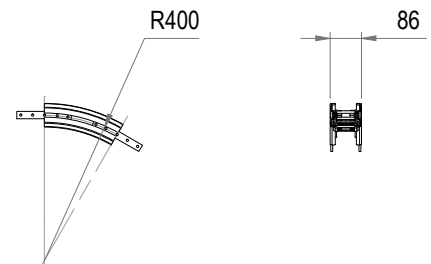

830-5620

VERTIKALKURVA 45° SERIE 830
VERTICAL BEND 45° SERIE 830
VERTIKALBOGEN 45° SERIE 830

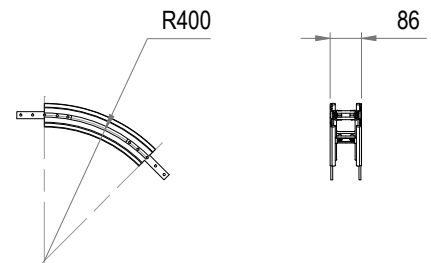

830-5630

VERTIKALKURVA 60° SERIE 830
VERTICAL BEND 60° SERIE 830
VERTIKALBOGEN 60° SERIE 830

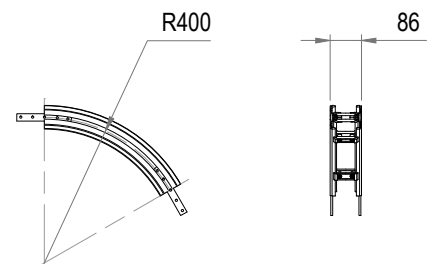

830-5640

VERTIKALKURVA 90° SERIE 830
VERTICAL BEND 90° SERIE 830
VERTIKALBOGEN 90° SERIE 830

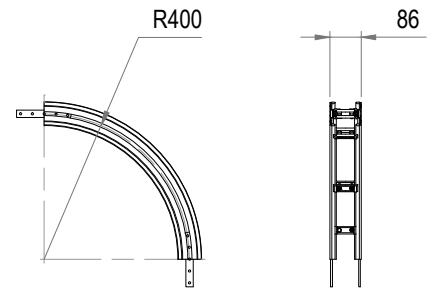

830-5645

VERTIKALKURVA X° SERIE 830
VERTICAL BEND X° SERIE 830
VERTIKALBOGEN X° SERIE 830

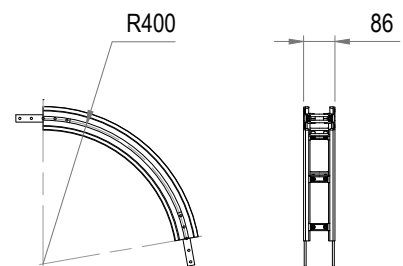

830-5650

VERTIKALKURVA 5° SERIE 830
VERTICAL BEND 5° SERIE 830
VERTIKALBOGEN 5° SERIE 830

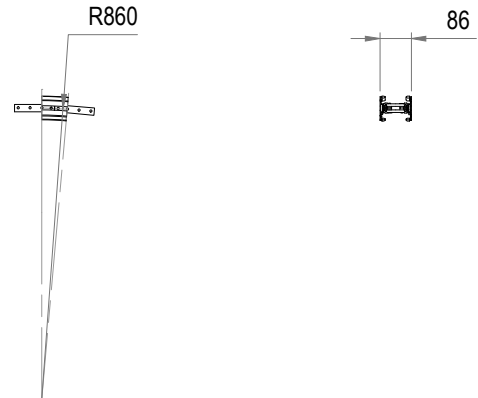

830-5660

VERTIKALKURVA 30° SERIE 830
VERTICAL BEND 30° SERIE 830
VERTIKALBOGEN 30° SERIE 830

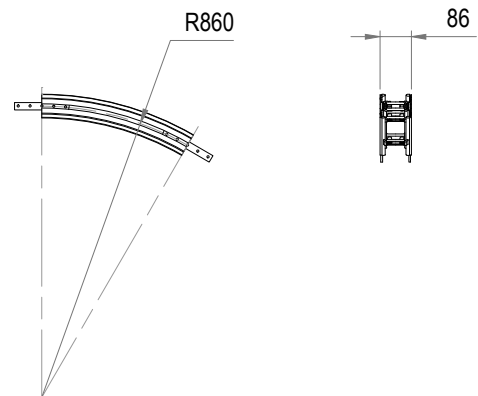

830-5670

VERTIKALKURVA 45° SERIE 830
VERTICAL BEND 45° SERIE 830
VERTIKALBOGEN 45° SERIE 830

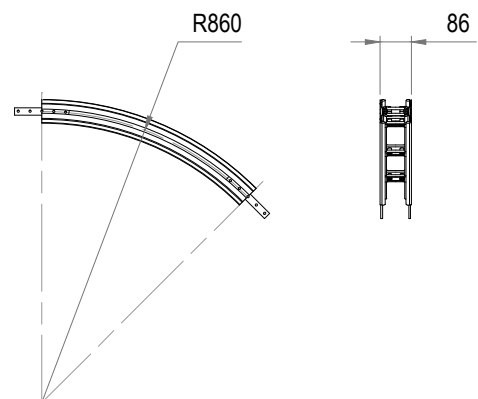

830-5680

VERTIKALKURVA 60° SERIE 830
VERTICAL BEND 60° SERIE 830
VERTIKALBOGEN 60° SERIE 830

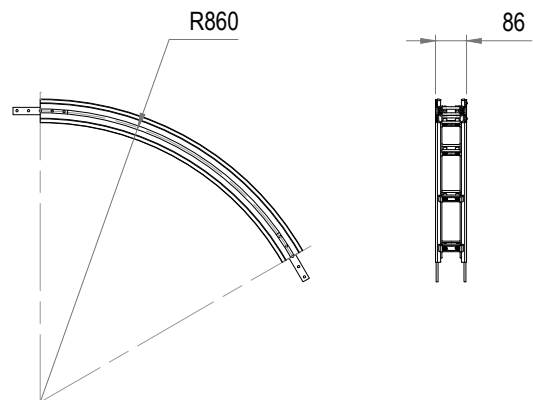

830-5690

VERTIKALKURVA 90° SERIE 830
VERTICAL BEND 90° SERIE 830
VERTIKALBOGEN 90° SERIE 830

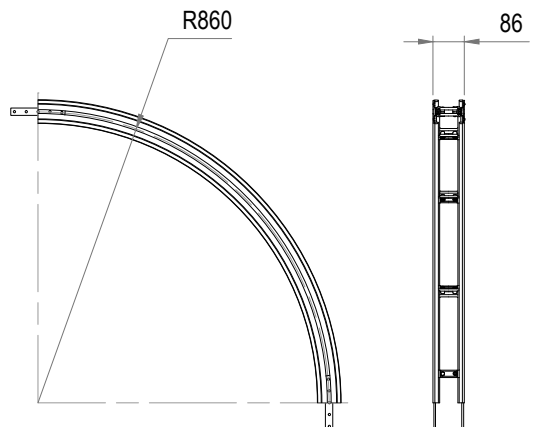

830-5695

VERTIKALKURVA X° SERIE 830
VERTICAL BEND X° SERIE 830
VERTIKALBOGEN X° SERIE 830

